

CD017	SIGNS AND ADVERTISING		
POLICY OWNER:	Shire of Carnarvon		
DEPARTMENT:	Regulatory Services		
CREATION DATE:		REVIEW SCHEDULE:	
LEGISLATION:			
DOCUMENT CONTROL			
DATE REVIEWED:	REVIEWED BY:	CHANGES (IF ANY):	APPROVED BY COUNCIL:
24/10/2024	Council	Creation	

CD0017 Signs and Advertising

Purpose

The purpose of this policy is to provide guidance on signage and instances where development approval is not required from the Shire of Carnarvon (the Shire). This policy also clarifies what signage is considered suitable by the Shire for approval to provide certainty to businesses.

This Policy sets out the matters the local government will consider when assessing applications for advertising signs.

This policy should be read in conjunction with Local Planning Scheme No. 13 and the Planning and Development (Local Planning Scheme) Regulations 2015.

Objectives

The objectives of this policy are to:

- (1) Ensure that the display of signs and advertisements on properties does not adversely impact upon the amenity of the area while providing appropriate exposure of activities or services.
- (2) To avoid the proliferation or abundance of signage within commercial and industrial areas.
- (3) To ensure that signs only relate to the services and products on the site.
- (4) To encourage the incorporation of advertising signs into the design consideration of buildings.
- (5) To protect the significance of heritage places and buildings.

Policy Area

All land that covers the district of the Shire of Carnarvon as shown on the Scheme Map.

Policy Statements

(1) Application

1. This policy applies to all advertisements as defined within Planning and Development (Local Planning Schemes) Regulations 2015. All references here within to the words 'sign' or 'signage' shall also be read as advertisement.

2. Where there is any inconsistency between this policy and any approved structure plan, local development plan and special control area then the provisions within those documents shall prevail.
3. In accordance with Clause 61 of the Planning and Development (Local Planning Schemes) Regulations 2015, development approval is not required where signage meets all the following:
 - i. Meets the criteria of the 'General Development Provisions' in Part (2) below;
 - ii. Meets the definition and provisions of the 'Permissible Signs and Standards' table in Part (5) below;
 - iii. Is not erected or installed within 1.5m of any part of a crossover or street truncation;
 - iv. Is erected within the boundaries of a lot;
 - v. Is not proposed on reserved land under the scheme; and
 - vi. Not located within a heritage protected place.
4. Where signage does not meet the criteria set out in Clause 3 above, development approval is required. Development applications shall be determined in accordance with clause 67 of Planning and Development (Local Planning Schemes) Regulations 2015.
5. Even if signage is exempt under Parts (2) and (4) or meets all criteria under Part (5), structures permanently fixed to the ground or a structure for a period exceeding 30 days in a calendar year require building approval.
6. Signs proposed on land reserved (partially or wholly) under the Scheme shall be referred to the relevant public authority in accordance with the relevant Western Australian Planning Commission (WAPC) Instrument of Delegation.
7. Signs proposed for properties on or adjacent to State Road Reserves require approval from Main Roads WA (Main Roads Control of Advertisements (1996)).
8. Development approval is required for all signage listed in the table in Part (6) below. The 'expectations' column of the table provides guidance on what the Shire would generally accept in relation to each type of sign.

(2) General Development Provisions

1. All signs shall:
 - a. Not pose a threat to public safety or health;
 - b. Only relate to services and products of the subject site;
 - c. Not consist of inappropriate or offensive language or material;
 - d. Not protrude over or located on Council property unless approval has been granted by the Shire;
 - e. Not comprise of flashing, intermittent or running lights; and
 - f. Have any electrical installation constructed and maintained to the satisfaction of Horizon Power or the appropriate authority in accordance with the S.A.A Code 3000-1991.

(3) Signs for Political Communication

1. In accordance with clause 61 of the Planning and Development (Local Planning Scheme) Regulations 2015, advertisements in connection with an election, referendum or other poll conducted under the *Commonwealth Electoral Act 1918* or the *Local Government Act 1995* or the *Referendums Act 1983* or the *Electoral Act 1907* do not require development approval if:
 - a. The primary purpose of the advertisement is for political communication
 - b. The advertisement is not erected or installed until the writ or writs have been issued or until the 36th day before a Local Government election
 - c. The advertisement is removed no later than 48 hours after the election, referendum or poll is conducted; and
 - d. The advertisement is not erected within 1.5m of any part of a crossover or street truncation.



(4) Existing Signage

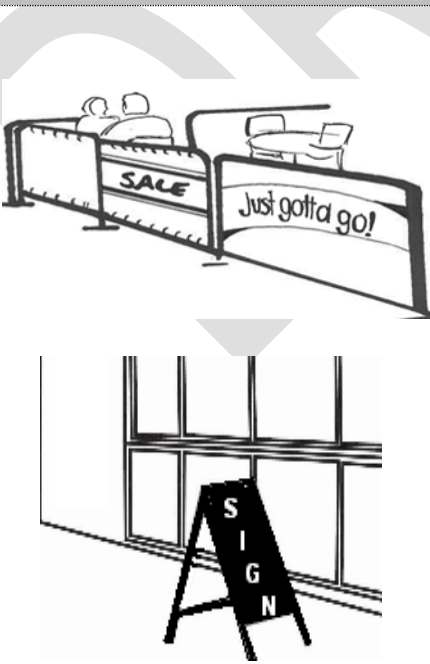

1. Existing signs which were erected, placed or displayed lawfully prior to this policy coming into force will not be impacted. Modifications to existing signs will be subject to this policy.

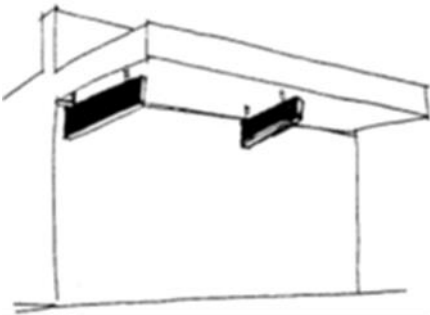
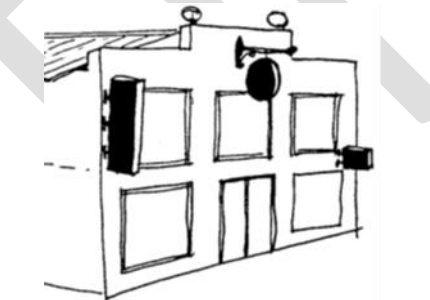
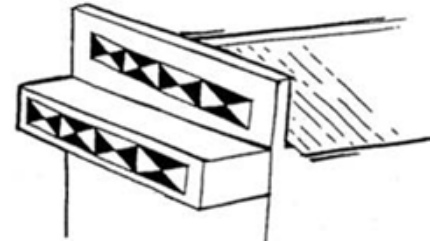

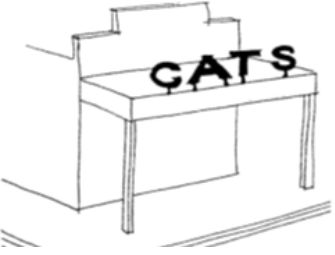
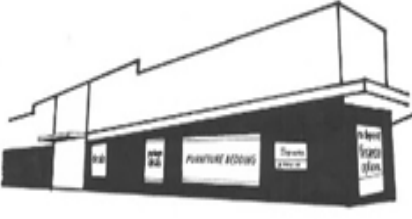
(5) Permissible Signs and Standards



	<u>Sign Type</u>	<u>Definition</u>	<u>Provisions</u>
1.	Ground Based and Portable Signs	A sign which is not attached or otherwise affixed to a building and no portion of which is higher than 1.2m above natural ground level.	<ol style="list-style-type: none"> a) Ground Based Signs – maximum size of 10m² in total. b) Portable Signs – maximum size of 2m² per sign with a maximum of 1m² on any one side. c) Multiple signs are permitted. d) All signs are to be secured and stabilised to the satisfaction of the Shire of Carnarvon to ensure they do not move/blow over in strong winds. e) Only be displayed during the opening hours of the business to which the sign relates.
			

	<u>Sign Type</u>	<u>Definition</u>	<u>Provisions</u>
2.	Awning Sign (below) 	A sign fixed to or suspended from the underside of a verandah, balcony or awning.	<ul style="list-style-type: none"> a) Is limited to one sign per tenancy on a lot. b) Is to have a minimum clearance of 2.4m above ground level. c) Is not to project beyond the outer frame or surround of the fascia of a verandah/awning. d) Is not to exceed 2.4m in length. e) Is to be at right angles to the street boundary.
3.	Projecting Sign 	A sign which projects from a wall of the building below the eaves or ceiling height.	<ul style="list-style-type: none"> a) Maximum size of 6m². b) Minimum headway/clearance of 2.4m. c) Shall not project more than 1m from the wall.
4.	Roof Sign 	A sign which is affixed to the fascia or parapet, or forms part of a projection above the eaves of the building.	<ul style="list-style-type: none"> a) Maximum size of 6m². b) Not located within 0.5m of either end of the external walls of the building.

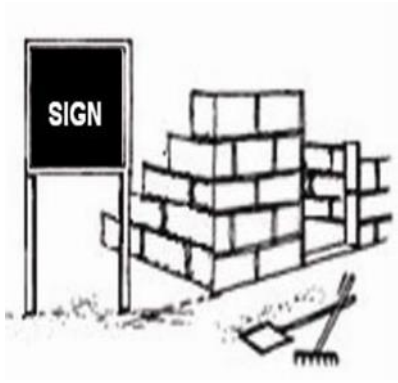
	<u>Sign Type</u>	<u>Definition</u>	<u>Provisions</u>
5.	Facia Sign (above)	A sign located above the outer fascia of a verandah, balcony or awning.	<ul style="list-style-type: none"> a) Maximum area of 6m². b) Letter shall not exceed 1m in height.
			
6.	Wall Sign	A sign which is affixed to the external part of a wall of the building but does not project above the lowest point of the eaves or ceiling of the building.	<ul style="list-style-type: none"> a) Not exceeding 25% in area on any one wall. b) Is not to be within 500mm of either end of the wall to which it is attached. c) Is not to project above the top of the wall. <p>Note: If the background colour of the sign matches the balance of the colour of the wall on which it is located, then the area of the sign shall be determined by measuring around the words of the sign.</p>
			
7.	Window Sign	Sign which is affixed to either the interior or exterior of the glazed area of a window.	<ul style="list-style-type: none"> a) Maximum size of 6m². b) Not exceeding more than 25% of the overall area of glazing of the individual façade. c) Lettering shall not exceed 1m in height.
			

	<u>Sign Type</u>	<u>Definition</u>	<u>Provisions</u>
8.	Real Estate Sign	A sign advertising the display, sale or lease of the property.	a) Maximum size of 6m ² . b) Limited to one sign per lot. c) Is not to be illuminated.
			
9.	Residential Property Sign	A sign affixed to, or located on, a residential property, and includes signs relating to Home Occupations and approved Home Businesses.	a) Maximum size of 0.5m ² . b) Only used for the purpose of identifying the name of the dwelling and/or nature of a Home Occupation or approved Home Business operating from the dwelling.
			
10.	Fence Sign	Any sign attached to a fence.	a) Maximum size of 6m ² per street frontage.
			
11.	Construction Sign	A sign which is displayed for the	a) Maximum size of 6m ² for single/grouped dwellings.

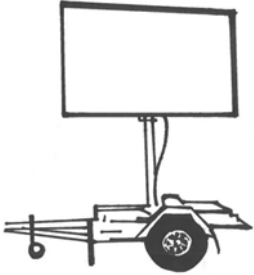

	<u>Sign Type</u>	<u>Definition</u>	<u>Provisions</u>
		<p>duration of the construction period which displays the project or contractor's details relating to the site.</p>	<ul style="list-style-type: none"> b) Maximum size of 12m² for multiple dwellings, commercial development not within centre zoned land and industrial development. c) Maximum size of 20m² for regional centre zoned development. d) In place for the duration of construction/development works only.
12.	<p>Safety/Warning Signs</p> 	<p>A sign which displays safety or warning messages relating to a potential hazard on or around a site.</p>	<ul style="list-style-type: none"> a) Necessary to comply with occupational, health and safety requirements.
13.	<p>Temporary Signs (for events)</p> 	<p>A sign which advertises an upcoming event.</p> <p>A sign which is permanent or portable and displays electronically generated variable messages.</p>	<ul style="list-style-type: none"> a) Maximum size of 6m². b) Exhibited up to a maximum of four (4) weeks prior to the event advertised and removed by the end of the day following the event.

	<u>Sign Type</u>	<u>Definition</u>	<u>Provisions</u>
14.	Variable Message Sign	A sign which is permanent or portable and displays electronically generated variable messages.	a) Used by public authorities for public purposes only.
			
15.	Advisory Sign	A sign erected on land which has been approved for subdivision and/or development, advertising the land/properties for sale.	a) Does not exceed 20m ² and a maximum dimension of 5m. b) One sign per subdivision/development. c) For subdivisions the sign shall be removed from the site within two years or when 80% of the lots in the subdivision have been sold, whichever comes first. d) For developments the sign is allowed to be in place for the duration of the construction works / development / transaction, period whereafter it must be removed.
			
16.	3D Replica Model or Shape/Object	A three-dimensional replica object or shape used as an advertising device and designated to replicate or copy a real world object or shape.	a) Maximum volume of 4m ³ . b) Maximum height of 5m. c) Must not be erected for more than 4 weeks in any 12-month period.

<u>Sign Type</u>	<u>Definition</u>	<u>Provisions</u>
		

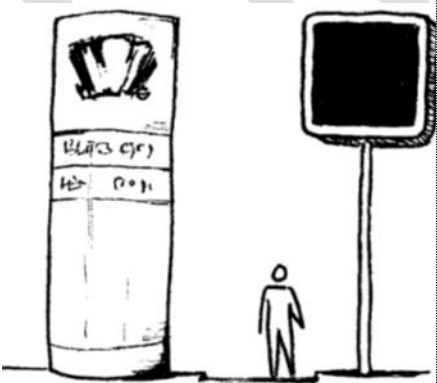
(6) Signage that Requires Development Approval

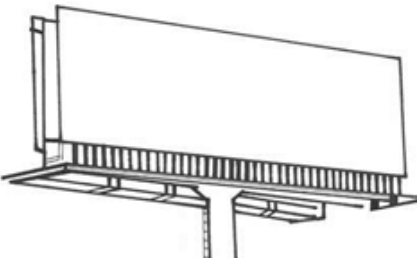
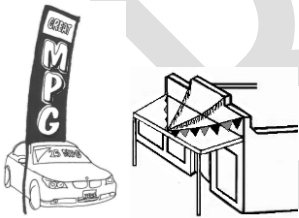
	<u>Sign Type</u>	<u>Definition</u>	<u>Expectations</u>
1.	Pylon Sign/Monolith Sign	A sign supported by one or more piers and not attached to a building.	<ul style="list-style-type: none"> a) Maximum size of 6m² per street frontage. b) Maximum height of 5m. <p>On any one lot, maximum of one sign per frontage, or one sign per 100 metres of frontage; whichever is the greater.</p> <ul style="list-style-type: none"> c) Setback a minimum distance of half its own overall height to the front property boundary. d) Setback 6m from any other sign erected on the same lot. e) Where there is more than one business tenancy on the lot, the sign shall be designed to accommodate advertising requirements of all tenancies.
			

	<u>Sign Type</u>	<u>Definition</u>	<u>Expectations</u>
			f) Is not permitted within a residential zone.
2.	Billboard Sign	A sign fixed to a free-standing structure that is not a building and has one or more supports.	a) Billboard signs are generally not supported unless the Shire deems that the sign has a public/community purpose. b) Mains Roads WA approval is also required for signs on State Roads reserves.
			
3.	Bunting/Flag/Tethered	A single or group of flags or material that may be freestanding or attached to a rope or line stretched between two or more points.	a) Bunting, flags and tethered signs should be low impact and not cause driver distraction. b) If the Shire resolves to approve flags or tethered signs, they should be removed when the business is closed.
			
4.	Product Display Sign	An object which is displayed for the purposes of advertisement; or an advertisement sign which is attached to or placed on a vehicle (car, truck, boat, trailer, caravan, machinery, whether moveable or not).	a) Product display signs are generally not supported within the Shire unless the sign has a public/community purpose.
			

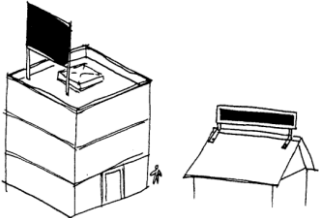
	<u>Sign Type</u>	<u>Definition</u>	<u>Expectations</u>
5.	Roof Sign (above)	A sign erected on or attached to the roof of a building.	<p>a) Not permitted if there is a roof sign on the same lot.</p> <p>b) Shall not project higher than 1m above the roof or 50% of the height of the building to which it is attached (whichever is higher).</p> <p>c) Not permitted in residential zones.</p>
			
6.	Any other sign not described in this policy		<p>a) Shall be to Shire of Carnarvon's discretion.</p>

(6) Signage on Heritage Sites

1. All signage erected on heritage sites require development approval
2. Signs shall contribute to the significance of a Heritage Place and existing signs should be retained and maintained.
3. Signs shall not dominate a heritage place. Instead, new signs should be placed where they would have traditionally been placed and should be limited to a level consistent with traditional coverage.
4. Signs should not be located where they would obscure or detract from a feature of the building and shall be located to ensure views to individually significant signs are maintained.
5. Installation of signage shall not result in physical damage to any significant fabric. Signage should be readily removable, with careful consideration given about the method of installation, in order to ensure that the original material can be reinstated.
6. If included on the State Heritage Register, shall be referred to the Heritage Council of Western Australia for comment.
7. Shall not require reproduction of historic advertising styles. Rather, respectful but clearly modern design is preferred for new signs.
8. Colours should be appropriate to the heritage place and in some instances which may require departure from standard company advertising colours.